

Total No. of Questions : 12

[Total No. of Printed Pages :3]

[4364]-712

B. E. (Petrochemical)

Examination - 2013

PROCESS DYNAMICS AND CONTROL

(2008 Pattern)

[Time : 3 Hours]

[Max. Marks : 100]

**Instructions**

- (1) Answer Q1 OR Q2, Q3 OR Q4, Q5 OR Q6, Q7 OR Q8, Q9 OR Q10, Q11 OR Q12.
- (2) Answers to the two **sections** should be written in separate **answer-books**.
- (3) Figures to the right indicate full marks.
- (4) Use of logarithmic tables, slide rule, Mollier charts, electronic pocket calculator and steam tables is allowed.
- (5) Assume suitable data, if necessary.

**SECTION-I**

Q.1) a) Explain the utility of Laplace transform in Process Control giving suitable example. [8]

b) What is the Role of Process Modeling and simulation in the design of a process control operation? [8]

OR

Q.2) a) Write a short note on design aspects of a process control system [8]

b) What do you mean by forcing functions? State various forcing functions with examples. [8]

Q.3) a) What do you mean by transfer function? Derive the Transfer function for the first order system. [8]

b) Derive the transfer function of a N- identical non-interacting system in series. [8]

Q.4) a) Define the following :

- |                                  |                          |      |
|----------------------------------|--------------------------|------|
| 1. Overshoot                     | 2. Period of oscillation |      |
| 3. Natural period of oscillation | 4. Rise time             |      |
| 5. Ultimate value of response    |                          | [10] |

b) Derive the overall transfer function for Regulatory problem of a negative feedback loop. [6]

Q.5) a) A proportional controller having  $K_c=6$  is used to control two first order non-interacting system having time constant 1 and 0.6. A unit step change is introduced into the set point of the control system.

Determine the maximum value of the response and the offset. [8]

b) A proportional controller is used for two non-interacting liquid system. The time constant for tanks are 1 and 0.5. The value of the gain of controller is 5. Assume unity feedback control system. The set point of the control system is given step change of magnitude 0.4. Determine the offset. [10]

OR

Q.6) a) Write short note on the following: [18]

- 1) Turning of controllers
- 2) Control Valve Characteristics
- 3) Role of automation and control in safety of a process

## SECTION-II

Q.7) a) A proportional controller having gain  $K_c$  is used to control two non-interacting liquid level tanks having time constant 1 and 0.5 respectively.

For the unity feedback control system. Determine the stability of the system using Routh criterion. [10]

- b) A proportional controller is used to control two non-interacting first order system having time constants 1 and 0.5 respectively. Assume unity feedback control system. Sketch the root locus diagram. [8]

OR

Q.8) a) What is a root locus diagram? Explain the method of plotting the Root locus diagram for negative feedback system. [9]

b) What is Bode Diagram? Explain the Bode diagram for first order system [9]

Q.9) a) With the help of suitable example and block diagram explain Ratio Control strategy. [8]

b) Draw a feedback and feed forward control for a Jacketed continuous stirred tank reactor for exothermal reactions . [8]

OR

Q.10) a) Explain with the help of a block diagram the Cascade control strategy [8]

b) Draw a Feedforward-feedback control of a distillation column [8]

Q.11) a) Explain with a block diagram the configuration of the supervisory control and data acquisition system (SCADA). [8]

b) Explain with example the application of Programmable logic control in process industry. [8]

OR

Q.12) a) Compare the programmable logic controller (PLC) with remote terminal unit RTU. [8]

b) Write a short note on Network communication Components of SCADA. [8]

[Total No. of Questions: 12]

[Total No. of Printed Pages: 4]

UNIVERSITY OF PUNE

[4364]-723

**B. E. (Petrochemical Engineering) Examination - 2013**

*PLANT DESIGN AND PROCESS ECONOMICS (2008 Course)*

[Time: 3 Hours]

[Max. Marks: 100]

**Instructions:**

- 1 Answer any three questions from each section.
- 2 Answers to the **two sections** should be written in **separate answer-books**.
- 3 Neat diagrams must be drawn wherever necessary.
- 4 Use of logarithmic tables, slide rule, Mollier charts, electronic pocket calculator and steam tables is allowed.
- 5 Black figures to the right indicate full marks.
- 6 Assume suitable data, if necessary.

**SECTION -I**

- Q.1 A What the important considerations are given for design of piping and piping layouts in process development? 6
- B Explain in detail various steps in design of any process plant? 6
- C Explain in detail the contents of Process License Agreement. 6
- OR**
- Q.2 A Discuss the Root Cause Analysis for **Any One** of the following: 6
- i) The 1984 Bhopal Gas Tragedy
- ii) The 2009 IOCL Jaipur Tank farm fire
- B What are the important considerations are to be given while making of Plant layout from safety, operations and maintenance point of view. 6
- C What do you mean by pilot plant? What is importance of pilot plant in process development? 6
- Q.3 A Draw a 'Design Basis Data Sheet' giving all specifications 8
- B Differentiate clearly between PFD, PBD and P&ID regarding their contents. 4
- C Draw a P&ID for a Shell and Tube Heat Exchanger. 4
- OR**
- Q.4 A Write a short note on **Any Two** of the following 16
- i) Project feasibility report
- ii) Annual Report of a company
- iii) Outside Battery Limits Facilities

- Q. 5 A A project has the following activities, activities duration and predecessors. 10  
Enrollment in local colleges, 2005

Activity	Duration (Days)	Predecessor
A	6	--
B	10	A
C	12	A
D	9	B,C
E	8	C
F	5	D,E

- i) Draw the PERT chart for this problem determine the critical path  
ii) Indicate the critical path on the PERT
- B Make Proforma for Shell and Tube Heat Exchanger 6  
**OR**
- Q. 6 A Write note on: 8  
i) Bar Chart & Gantt Chart  
ii) HAZOP & HAZEN
- B Discuss the Fulkerson's Rule to number the activity and event. Discuss the 'Three Time estimates' in PERT/CPM network. How Earliest expected time (TE) is calculated? Discuss with help of suitable network sketch. 8

## SECTION II

- Q. 7 A Explain the relationship between Process Design and Process Economics with proper justifications. 4  
B Define the following financial ratios: 8  
i) Current Ratio  
ii) Acid test ratio  
iii) Equity ratio  
iv) 4. Operating Margin
- C What is Cost Index? Give the details of the most commonly used cost indexes by Chemical Engineers. 6  
**OR**
- Q. 8 A What are the components of Total Capital Investment (TCI)? 10  
Compare Standard methods of TCI with respect to the following:  
i) Basic of estimation  
ii) %Error in estimation  
iii) Its application
- B On April 1, 2012, company purchase equipment at the cost of Rs. 1,60,000. This equipment is estimated to have 5 years useful life. At the end of 5<sup>th</sup> year, the scrap value will be Rs. 20,000. Company A recognizes depreciation to the nearest whole month. Calculate the depreciation expenses for 2010, 2011 and 2012 using following methods: 8  
i) Straight-line depreciation method.  
ii) Declining balance depreciation method  
iii) Double declining balance depreciation method  
iv) Sum of Years digit method

Q. 9 A With reference to **Table1**, Evaluate the following financial ratios:

8

- i) Current Ratio
- ii) Acid test ratio
- iii) Equity ratio
- iv) Operating Margin

**Table 1**

**Balance Sheet for ABC Company (Units in Rupees x 10<sup>3</sup>)**

<b>ASSETS</b>			
Current assets			
Cash, Inventory, Acc Rec and other	4,630		
Total current assets		4,630	
Investments+ Property		9,581	
Total Assets			14,211
<b>LIABILITIES</b>			
Current (4153)+ Noncurrent Liab.		9,850	
Total Liabilities			9,850
<b>STOCKHOLDERS' EQUITY</b>			
Common stock	5,230		
Retained earnings	2,559		
Less treasury stock	(3,428)		
Net Stockholders Equity			4,361
Total liabilities+Stockholders Equity			14,211

**Income Statement for ABC COMPANY (Units in Rupees x10<sup>3</sup>)**

Net sales	11,504	
Cost of Goods sold	3,131	
<b>GROSS PROFIT</b>		2,373
<b>OPERATING EXPENSES</b>		
Research and Development	446	
Selling, general, and administrative	439	
Insurance and finance	34	
Amortizatiz and adjustments of goodwill	64	
<b>TOTAL OPERATING EXPENSES</b>		983
<b>INCOME FROM OPERATIONS</b>		1,390
Interest expenses	185	
<b>GROSS INCOME</b>		1,205
Provision from income tax	402	
<b>NET INCOME</b>		803

B Company X is considering the Projects that have the following costs: (All cost are in Rupees) 10

<b>Activity</b>	<b>Duration (Days)</b>	<b>Predecessor</b>
First cost	15000	18000
Annual Operating costs	3500	3100
Salvage Value	1000	2000
Life, years	6	9

- 
- i) Using money worth 15% per year, determine which alternative should be selected on the basis of a present-worth analysis.
  - ii) Company X has a standard practice of evaluating all projects over a 5-year period. If a study period of 5 years is used and the salvage values are expected to be Rs.1500 and Rs.4000 for A and B respectively, which project should be selected?

**OR**

- |           |   |   |    |
|-----------|---|---|----|
| Q. 10     | A | Write short note on: Costing of process utilities   | 8  |
|           | B | Write a Short note on : Taxes and insurance.  | 8  |
| Q. 11     | A | Explain in detail the Break Even Analysis for economic evaluation of the Petrochemical Engineering project. | 10 |
|           | B | What do you mean by Sensitivity Analysis of a project? How it is done?                                      | 6  |
| <b>OR</b> |   |   |    |
| Q. 12     | A | Write a short note on the following:  | 16 |
|           |   | i) Product Pricing  |    |
|           |   | ii) Annualized cost   |    |
|           |   | iii) Capitalized cost   |    |
|           |   | iv) Pay back period   |    |

[Total No. of Questions: 8]

[Total No. of Printed Pages: 2]

UNIVERSITY OF PUNE

[4364]-725

**B. E. (Petrochemical Engineering) Examination - 2013**

*FINE CHEMICAL INDUSTRIES (2008 Course)*

[Time: 3 Hours]

[Max. Marks: 100]

**Instructions:**

- 1 *Answer 3 questions from Section I and 3 questions from Section II*
- 2 *Answers to the two sections should be written in separate answer-books.*
- 3 *Neat diagrams must be drawn wherever necessary.*
- 4 *Figures to the right indicate full marks.*

**SECTION -I**

- |     |   |   |    |
|-----|---|---|----|
| Q.1 | A | Mention the differences in processes used for manufacturing fine chemicals and commodity chemicals                                    | 10 |
|     | B | Discuss environmental and safety aspects in process development   | 8  |
| Q.2 | A | Explain how a catalyst is selected for a process.   | 10 |
|     | B | State principles of good manufacturing practice in fine chemicals   | 6  |
| Q.3 | A | Discuss batch distillation and azeotropic distillation as methods of separation with specific reference to fine chemicals manufacture | 10 |
|     | B | Mention outlets for fine chemicals  | 6  |



- Q. 4      A      Explain with example ideas of mixed plants for used in preparation of fine chemicals      10
- B      Discuss with example how catalyst helps in waste minimization.      6

## SECTION II

- Q. 5      A      Discuss criteria and constraints in production planning scheduling and design of batch plants.      12
- B      Write a note on scale-up procedures.      6
- Q. 6      A      Take a short review of different separation processes used in manufacture of fine chemicals.      10
- B      Write a note on zeolites as adsorbents in fine chemical industry.      6
- Q. 7      A      Discuss applications of ion exchange resins in preparation of fine chemicals.      10
- B      Discuss the contribution of fine chemical sector to national economy      6
- Q. 8      A      Discuss      16
- a) Extraction processes
- b) Homogeneous catalysis

**UNIVERSITY OF PUNE**  
**[4364]-711**  
**BE.(PETROCHEMICAL) Examination - 2013**  
**REACTION ENGINEERING - II**  
**(June 2008 Pattern)**

**Total No. of Questions : 8**  
**[Time: 3 Hours]**

**[Total No. Of Printed Pages: 3]**  
**[Max. Marks: 100]**

**Instructions :**

- (1) Answer **any three** questions from each section.
- (2) Answers to the **two sections** should be written in **separate answer-books**.
- (3) *figures to the right indicate full marks.*
- (4) *Assume suitable data, if necessary.*
- (5) *Use of steam tables and electronic calculator is allowed.*

**SECTION-1**

Q. 1. a) Explain the important steps involved in Langmuir-Hinshelwood mechanism. (6)

b) Suggest an appropriate kinetic equation useful in laboratory data interpretation for catalytic synthesis of methanol from synthesis gas. Assume surface reaction on catalyst to be rate controlling. (10)

Q. 2. a) Define Effectiveness Factor and Thiele Modulus. Derive the expression giving generalized effectiveness factor. (10)

b) We want to design a **fixed** bed reactor filled with 2.0-cm porous catalyst particles (catalyst density is  $2500 \text{ kg/m}^3$  and effective diffusivity is  $2.5 \times 10^{-6} \text{ m}^2/\text{s}$ ) to treat  $3 \text{ m}^3/\text{s}$  of feed gas (1/3 A, 1/3 B, 1/3 inert) at 350 C and 8 bar to 95% conversion of A. Experiments with fine catalyst particles, which are free from diffusional resistance, show that the gas phase reaction  $A \rightarrow R + S$  is first order with rate constant based on weight of catalyst given as 0.08 SI units. Calculate the mass of catalyst needed to be placed in the fixed bed reactor. (8)

Q.3. a) Derive from the first principals time conversion relationship for the case of A first order reaction on a deactivating catalyst if deactivation kinetics is also first order in catalyst activity. Assume mixing patterns for both solids and fluid as equivalent to batch reactor. (8)

b) Discuss the mechanisms responsible for poisoning of the catalyst. (8)

Q. 4. Write notes: (16)

a) Merits and de-merits of fixed and fluid bed reactors

b) Non-isothermal catalyst reactor design

## SECTION-2

Q. 5. With reference to the design of gas-liquid column, derive the following: (16)

a) Design equation for calculating height of the column

b) Expression for rate of absorption when a component of dilute gas undergoes 1) instantaneous reaction in liquid film and 2) fast reaction spread over the liquid film.

Q. 6. An acidic impurity A in gaseous stream is to be removed so as to reduce its partial pressure from 450 Pa to 30 Pa (total pressure is 120 KPa) by reacting it with a base B dissolved in water in a packed tower operated in a counter current manner. Overall gas side mass transfer coefficient is  $0.01 \text{ mol/hr.m}^3 \cdot \text{Pa}$ . Gas side resistance to mass transport in absence of the reaction is 20% whereas the liquid film contributes the remaining 80% resistance. Henry's constant is  $18 \text{ Pa.m}^3/\text{mol.L/G}$  ratio is 6 times the minimum required for plain absorption. Calculate minimum concentration of B needed at the top of the tower to ensure minimum height of the tower. Also report this minimum height. (18)

Q. 7. a) Derive time-conversion relationship for a flat-plate shaped particle reacting With a gas in a uniform atmosphere when diffusion to gas transport through the ash layer is controlling the overall rate. (10)

b) Flat plate of ZnS with initial thickness of 3 cm is subjected to roasting in presence of air. Roasting reaction yields  $\text{SO}_2$  as also the layer of ZnO. Molar density of solid may be assumed to be  $0.04 \text{ mol/cm}^3$ . Diffusivity Of gas through the product layer is  $0.06 \text{ cm}^2/s$ . Calculate the time required to reduce the ZnS core of the plate by 85%. (6)

Q.8. Give a brief account of pertinent reactions, Catalyst used, operating conditions and reactors employed in any two important refinery conversion processes of your choice. (16)

**UNIVERSITY OF PUNE**  
**[4364]-713**  
**B.E. (Petrochemical Engg)**  
**Examination – 2013**  
**Environmental Engineering**  
**(2008 Pattern)**

**Total No. of Questions : 12**

**[Total No. of Printed Pages :3]**

**[Time : 3 Hours]**

**[Max. Marks : 100]**

**Instructions :**

- (1) Answer **three** questions from section I and three question from section II.
  - (2) Answers to the **two sections** should be written in **separate answer-books**.
  - (4) Neat diagrams must be drawn wherever necessary.
  - (5) Use of logarithmic tables, slide rule, Mollier charts, electronic pocket calculator and steam tables is allowed.
  - (6) Assume suitable data, if necessary.
- 

**Section I**

- Q1. a) What are the various types of Hazardous waste & their treatment methods? [10]  
b) Describe the impact of man on the Environment. [6]  
OR
- Q2. a) Explain the Clean development Mechanisms? [8]  
b) State the effects resulting due to ozone layer deletion. [8]  
OR
- Q3. a) Classify the various air pollutants & its sources. [8]  
b) Why ESPs- Electrostatic Precipitators mandatory for Cement plants? Explain the working of ESPs. [8]  
OR
- Q4. a) Discuss the methods for Air pollution sampling & measurement. [8]  
b) What are the Air pollution control laws for coal fired Thermal Power Generation plants? [8]

Q5. a) What are the waste generation from Fertilizer industries? How are these waste treated? [8]

b) What is Plume behavior? What are the conditions required for the formation of plumes [10]

OR

Q6. a) Write a short note on following: [18]

- 1) CDM
- 2) Kyoto Protocol
- 3) Carbon credits
- 4) COD/BOD ratio
- 5) Green House effect
- 6) Temperature lapse rates & stability.

## Section II

Q7. a) What are the General Standards for quality of water for different purposes? [8]

b) What is Chemical Oxygen demand? Can we determine tentative BOD of waste water if its COD is known? How? Give limitations of BOD test. [8]

OR

Q8. a) Name at least five physical and chemical waste water characteristics. [5]

b) Discuss the role of CPCB. [5]

c) What is TDS? Why TDS limit of 2100mg/L is specified for wastewater prior to discharge to the river? [6]

Q9. a) Explain working of any one sludge treatment and disposal method. [8]

b) Discuss principle, construction, working, advantages and disadvantages of Activated Sludge process with neat sketch. [8]

OR

Q10. a) Discuss the method of removal of suspended and dissolved solids. [8]

b) Explain the various methods for removal of nitrogen & phosphorous from wastewaters. [8]

Q11. a) Discuss the sources and method of treatment for Fertilizer industry waste with neat sketch. [9]

b) Discuss the sources and treatment method for waste from steel plant industry, [9]

OR

Q12) Write a short note on (Any three)

[18]

- a) OSHA
- b) Importance of regulations for hazardous waste.
- c) Conventional sewage treatment
- d) Sanitary land filling operations
- e) ISO 14000

**UNIVERSITY OF PUNE**  
**[4364]-715**  
**B. E.(Petrochemical Engineering)Examination - 2013**  
**NOVEL SEPARATION PROCESSES (ELECTIVE-I)**  
**(2008 Pattern)**

[Total No. of Questions:12]  
[Time : 3 Hours]

[Total No. of Printed Pages :4]  
[Max. Marks : 100]

***Instructions :***

- (1) Answer **any three** from each section.
  - (2) Answers to the **two sections** should be written in **separate answer-books**.
  - (3) Black figures to the right indicate full marks.
  - (4) Neat diagrams must be drawn wherever necessary.
  - (5) Use of logarithmic tables, slide rule, Mollier charts, electronics pocket calculator is allowed.
  - (6) Assume suitable data, if necessary.
- 
- 

**SECTION-I**

Q1 a) Discuss in brief rate based and equilibrium based separation processes [9]  
by giving suitable examples.

b) Discuss in brief the criteria for energy requirements for separation processes [9]  
by giving suitable examples.

**OR**

Q2 Attempt Any Three of the following: [18]

a) Compare and contrast on Macroemulsions and Microemulsions with suitable examples

b) Discuss the process principles involved in Ultrafiltration Nanofiltration and Microfiltration

c) Discuss in brief process principles in Foam Fractionation

d) Write a brief note on: "Hydrotopes".



e) Discuss various membrane materials with their properties.

Q3 State various models available for gas separation by membranes. Derive [16] the model equation for complete mixing model for gas separation by membranes. Discuss the solution strategies for the various cases in the final model equations

**OR**

Q4 Discuss in detail with neat sketches various membrane modules. State [16] merits and demerits of each module with applications in membrane separation processes.

Q5 a) A heart-lung machine uses a 0.175 mm silicone rubber membrane with [8] a permeability of  $6.4 \times 10^{-7} \text{ cm}^3 \text{ O}_2 \text{ (STP) mm/s.cm}^2\text{cmHg}$ . The machine is to supply  $355 \text{ cm}^3/\text{min}$  of oxygen to a patient, where the partial pressure of oxygen in the blood is the equivalent of 35 mmHg. The machine is supplied with pure oxygen at 700 mmHg, so gas film resistance can be neglected. If the resistance on the blood side were neglected also, estimate the membrane area for this application?

**OR**

b) Discuss the models available for reverse osmosis. Derive flux equations [8] for diffusion type model.

Q6 An 9-micron tubular membrane is used to recover salt A from a dilute [16] solution. The solutions to either side are at 0.023 and 0.004 kmol/m<sup>3</sup>, with mass transfer coefficients of  $3.4 \times 10^{-5}$  and  $2.25 \times 10^{-5} \text{ m/s}$  respectively. The distribution coefficient is 0.80 and the diffusivity of A in the membrane is  $2.95 \times 10^{-11} \text{ m}^2/\text{s}$ .

i) Calculate the percentage of total resistance to mass transfer contributed by the membrane.

ii) Calculate the membrane area needed to allow recovery at 0.015 kmol/hr.

iii) Flow inside the tube is turbulent and mass transfer follows the Gilliland, Sherwood and Linton correlation. If the velocities of both solutions are doubled, estimate the membrane resistance in this case?

## SECTION-II

Q7 a) Discuss the process principles involved in Pressure Swing Adsorption (PSA) with industrial applications. [6]

b) Discuss in brief equilibrium relation for adsorbents [6]

c) Discuss various adsorbents with their properties [6]

### OR

Q8 Activated carbon is used to absorb ethanol vapor from an airstreams. The [18]  
Lab experiment to investigate this has a bed 6 cm in diameter and 17 cm high. Exit data for an input of 0.750 liter/second are as follows:

Time (hours)	0	3	3.5	4	4.5	5	5.5	6.0	6.2	6.5	6.8
C/C <sub>0</sub>	0	0	0.002	0.030	0.15	0.39	0.65	0.90	0.94	0.97	0.99

i) Determine breakthrough time if break point is  $C/C_0=0.05$

ii) Calculate the height of a new column of the same diameter that has breakthrough at 9 hours.

iii) Calculate the diameter of this new column if it is to process 3 liter/min.

Q9 a) 1200 ml of water has 144 grammes of glucose dissolved in it. If the [8]  
solution is mixed with 500 grammes of virgin activated alumina, how much glucose will remain in solution when equilibrium has been reached?

b) In a given run using a flow rate of  $0.2 \text{ m}^3/\text{hr}$  in an ion-exchange tower [8]  
with a column height of 0.4m, the break point occurred at 8 min. The ratio of usable capacity to total capacity is 0.65. What is the height of similar operation for 13 min. to the break point at the same flow rate?

### OR

Q10 a) In gas chromatography, a plot of HETP as a function of the mobile [6]  
phase velocity is described by the Van Deemter equation:

$$\text{HETP} = A + B/u + Cu$$

Physically, what do the terms A, B and C represent? Calculate the optimum value of the mobile phase velocity and the plate height in terms of these parameters.

b) Classify chromatographic separation techniques. Discuss the process fundamentals involved in elution chromatography [10]

Q11 a) Discuss in brief the process principles and operational fundamentals involved in Ion Exchange separations. [8]

b) Discuss the process principles involved in Super critical fluid extraction. State its industrial applications. [8]

**OR**

Q12 Write Short notes on (any three) [16]

i) Reactive Separations

ii) Isoelectric Focusing

iii) Bioseparation

iv) Electrophoresis

**UNIVERSITY OF PUNE**  
**[4364]-716**  
**B. E. (PETROCHEMICAL) Examination 2013**  
**ELEMENTS OF FLUIDIZATION ENGINEERING**  
**(2008 Course)**

[Total No. of Questions:12]  
[Time : 3 Hours]

[Total No. of Printed pages :3]  
[Max. Marks : 100]

*Instructions :*

- (1) *Solve Any 3 questions from each SECTION.*
  - (2) *Answers to the two Sections should be written in separate answer-books*
  - (3) *Neat diagram must be drawn wherever necessary.*
  - (4) *Figures to the right indicate full marks.*
  - (5) *Assume suitable data, if necessary.*
  - (6) *Use of logarithmic tables slide rule, Mollier charts, electronic pocket calculator and steam tables is allowed.*
- 
- 

**SECTION I**

Q.1a) Give a comparative statement of different types of contacting mechanisms for Reacting Gas-Solid systems. [10]

b) With help of neat diagram explain the process of fluidization. [6]

**OR**

Q.2a) State advantages and disadvantages of fluidized bed over fixed bed [8]

b) With help of diagram explain the liquid like behavior of fluidized bed systems. [8]

Q.3a) Write a short note on Geldart's classification of particles and their important characteristics. Provides suitable examples also. [8]

b) Calculate the minimum fluidization velocity  $u_{mf}$  for a bed of crushed anthracite coal fluidized by gas. [8]

$$\rho_s = 2.0 \text{ gm/cm}^3, \quad \rho_g = 1.22 \times 10^{-3} \text{ gm/cm}^3, \quad d_p = 100 \mu\text{m},$$

$$\phi_s = 0.63, \quad \epsilon_{mf} = 0.47, \quad \mu_g = 1.8 \times 10^{-4} \text{ gm/cm.s}$$

$$L_{mf} / d_t = 3$$

**OR**

Q.4a) Obtain the mathematical expression of fluidization velocity based on first principles model. [8]

b) With help of neat diagram explain the operation of Tuyeres type distributor used in fluidized bed – Highlight its advantages and disadvantages also. [8]

Q.5a) Discuss the difficulties in measurement of multiphase flow. In this context highlight the ideal characteristics of multiphase flow meter. [10]

b) Discuss the pressure drop velocity diagram in details. In this context explain the minimum fluidization velocity and its significance. [8]

**OR**

Q.6 Write short notes on(any three): [18]

- i) Circulating Bed Fluidized bed
- ii) Coalescence and Splitting of Bubbles
- iii) Pneumatic Transport
- iv) Quality of Fluidization

## **SECTION II**

Q.7a) Immersed tubes can enhance heat transfer coefficient of fluidized bed to a great extent – Explain with help of neat diagram. [8]

b) With help of suitable mathematical expressions explain gas interchange between bubble and emulsion phase. [8]

**OR**

Q.8a) What are different variables affecting heat transfer rate in fluidized bed – Explain in details. [8]

b) How can fluidized bed heat transfer be used commercially – Explain with help of suitable examples. [8]

Q.9a) Discuss qualitatively various types of models available for Fluidized bed reactors. [8]

b) With help of suitable diagrams discuss flow of gas through bubbles for slow moving and fast moving bubbles. [8]

**OR**

Q.10a) With help of important assumptions derive Kunii- Levenspiel model for the bubbling fluidized bed. [10]

b) Discuss the effect of temperature and pressure on fluidized beds. [6]

Q.11a) Explain the operation of Fluidized bed Polyethylene Manufacturing unit with help of schematic diagram – discuss its advantage over earlier process. [10]

b) Discuss fluidized bed operation for synthesis of liquid fuel from biomass. Provide neat diagram of the process and clearly mention all the possible reactions involved. [8]

**OR**

Q.12 Write short notes on (any three): [18]

- i) Mass Transfer in Fluidized Bed
- ii) Scale up of Fluidized Bed Systems
- iii) Freeboard Region and its Utility
- iv) FCC Reactor

UNIVERSITY OF PUNE

[4364]-717

B. E. (Petrochemical Engineering) Examination - 2013

(Elective I)(Green Chemistry)( 2008 Course)

[Total No. of Questions:8]

[Total No. of Printed Pages: 2]

[Time: 3 Hours]

[Max. Marks: 100]

**Instructions:**

- 1 Answers to the **two sections** should be written in **separate answer-books**.
- 2 Draw neat diagrams wherever necessary.
- 3 Numbers to the right indicate **full marks**.
- 4 Answer **any three** questions from each section.

**SECTION -I**

- Q.1 State in brief the twelve principles of green chemistry. 18  
Discuss in detail any three of them with reference actual application.
- Q.2 A Explain the use of supercritical CO<sub>2</sub> as a green agent in chemical processing. 10  
B Explain characteristic properties of ionic liquids making them potential green solvents in industrial applications. 6
- Q. 3 A Distinguish between conventional and green manufacture using an example of your choice. 8  
B Write a note on green catalysis used for oxidation. 8
- Q. 4 A Explain with example: 10  
1. Enzyme driven reactions  
2. Photochemistry as green chemical process.  
B Explain phase transfer catalysis with an example. 6

## SECTION II

Q. 5	Discuss:	
	A	Environmental management systems. 10
	B	Uses and storage of solar energy. 8
Q. 6	A	Discuss technologies for biomass conversion into useful chemical products. 10
	B	Discuss process intensification with an example. 8
Q. 7	A	Describe the green route for preparation of lactic acid. 10
	B	Discuss the causes of carbon build-up in the atmosphere. 6
Q. 8	Discuss	16
	a.	Microwave Assisted Chemical Reactions
	b.	Electrochemical Organic Synthesis



UNIVERSITY OF PUNE

[4364]-720

B. E. (Petrochemical Engineering) Examination 2013

NATURAL GAS TECHNOLOGY

(2008 Course)(412405C)(SEMESTER I)

[Total No. of Questions:]

[Total No. of Printed pages :3]

[Time : 3 Hours]

[Max. Marks : 100]

*Instructions :*

- (1) *Answers Q.1 or Q.2, Q.3 or Q.4, Q.5 or Q.6, Q.7 or Q.8, Q.9 or Q.10, Q.11 or Q.12.*
- (2) *Answers to the two Sections should be written in separate answer-books*
- (3) *Neat diagram must be drawn wherever necessary.*
- (4) *Figures to the right indicate full marks.*
- (5) *Assume suitable data, if necessary.*
- (6) *Use of logarithmic tables slide rule, Mollier charts, electronic pocket calculator and steam tables is allowed.*

**SECTION I**

- Q.1 a) Discuss the outlook for world gas production [8]  
b) Elaborate on formation of natural gas reservoirs [8]

**OR**

- Q.2 a) Elaborate on different types of natural gas composition and regional Disparities. [8]  
b) Describe the origin of natural gas [8]
- Q.3 a) Explain in detail sampling methods of natural gas [8]  
b) Discuss well selection, conditioning and sampling of condensate gas [6]  
c) Elaborate on viscosity of gas mixtures [4]

**OR**

- Q.4 a) Discuss the components present in the natural gas [8]  
b) Find the viscosity for a gas with composition in mole % of  $C_1=90.5$ ,  $C_2=2.3$ ,  $C_3=2.3$  at 3000 psia and 540<sup>o</sup>R. [6]

Component	Mi	Pci	Tci	$\mu_{lgi}$
C <sub>1</sub>	16.043	667.8	343.1	0.0110
C <sub>2</sub>	30.070	707.8	549.8	0.0092
C <sub>3</sub>	44.097	616.3	665.7	0.0082

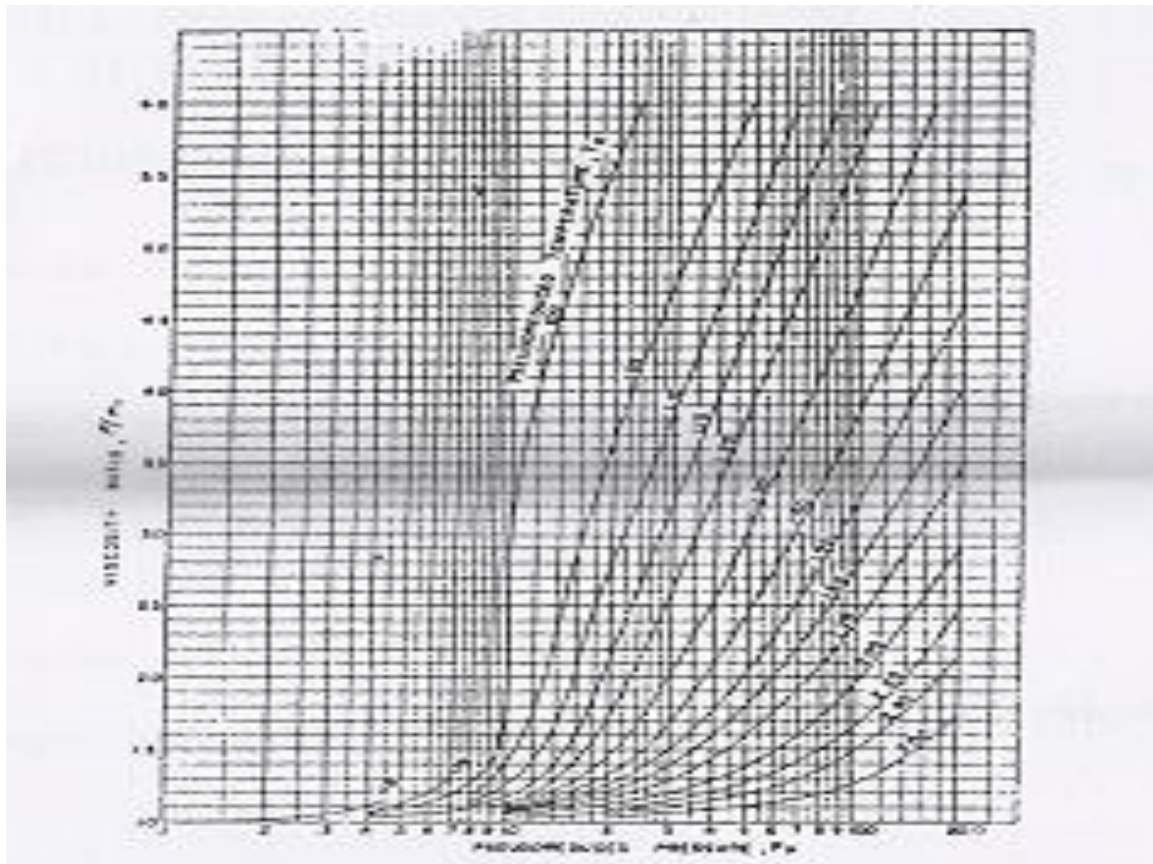

c) Draw phase diagrams of a dry gas and a wet gas showing conditions in the reservoir as well as at the surface and describe the same in brief [4]

Q.5 a) Explain in detail equilibrium cell for determining hydrate formation Point. [6]

b) Explain in detail predicting hydrate formation by equilibria chart method [6]

c) Write a short note hydrate inhibitors [4]

**OR**

Q.6 a) Explain in detail modeling hydrate formation equilibria [6]

b) Describe in detail nucleation step in hydrate formation [6]

c) Write a short note on water content of natural gas [4]

**SECTION II**

Q.7 a) Explain in detail dehydration of natural gas by adsorption [8]

b) Discuss in detail gas permeation [8]

**OR**

Q.8 a) Describe with flow sheet compression refrigeration cycle for [8]

natural gas.

- b) Explain with flow sheet acid gas removal by selexol process. [8]
- Q.9 a) Discuss design of pipeline transport installations [6]
- b) Explain with flow sheet natural gas liquefaction using TEALARC process with two pressure levels [6]
- c) Write a short note on LNG carriers [6]

**OR**

- Q.10 a) Explain in detail construction and working of axial flow compressors [6]
- b) Elaborate on existing LNG terminal in India
- c) Describe in detail different gas chains [6]
- Q.11 a) Describe with flow sheet Fisher-Tropsch synthesis process in fixed-bed reactors [8]
- b) Write a short note on [8]
- i) Production of gasoline from methanol
- ii) Thermal coupling process

**OR**

- Q.12 a) Describe in detail production of higher alcohols and ethers from methane [8]
- b) Write a short note on natural gas storage

[Total No. of Questions: 12]

[Total No. of Printed Pages: 3]

UNIVERSITY OF PUNE

[4364]-724

T. E. (Petrochemical Engg) Examination - 2013

Process modeling and simulation (2008 Course)

[Time: 3 Hours]

[Max. Marks: 100]

**Instructions**

:

- 1 Answer 3 Que. from Section I and 3 Que. from Section II
- 2 Answers to the two sections should be written in separate answer-books.
- 3 Black figures to the right indicate full marks.
- 4 Neat diagrams must be drawn wherever necessary.
- 5 Use of, electronic pocket calculator is allowed.
- 6 Assume suitable data, if necessary.

**SECTION -I**

- Q.1    A    Explain Lumped and Distributed parameters. Compare them with reference to a tray in a distillation column.    08
- B    Discuss the applications of microscopic and macroscopic systems in process modeling.    08

**OR**

- Q.2    A    With neat flowchart, note in details steps in modern process design strategy.    16
- Q. 3    A    In a refinery process, a gas absorption column is used to purify the gas feed stream entering from the bottom. The liquid Absorbent enters from the top. Develop solute balance equations for a typical equilibrium stage I, Top stage and bottom stage.    18

**OR**

- Q. 4    A    Reactant A is fed as a gas through a distributor into the bottom of the liquid filled in a bubble column reactor. A chemical reaction occurs between A and B in the liquid phase to form a liquid product C. Develop mathematical expressions describing the

system.

B Develop Mathematical model for a multistage counter current extraction system. 08

Q. 5 A Solve using Newton Raphson method: 16  
 $\sin x - x \cos x = 0$   
Assume initial guess value for  $x = 3 \times \pi / 2$ . Perform the calculations till the accuracy of function is 0.00001.

OR

Q. 6 A A gas is expanded according to a law of  $PV^{1.3} = \text{constant}$ , from 16  
pressure of  $10 \text{ N/m}^2$ . Assuming initial volume of gas as 1 cubic meter and final volume as 7 cubic meter, calculate work done by dividing volume in 6 equal intervals. Use Simpson's 1/3 rule.

### SECTION II

Q. 7 A LPG is fed into pressurized tank to hold the liquid level in the 18  
tank, as shown in the fig:

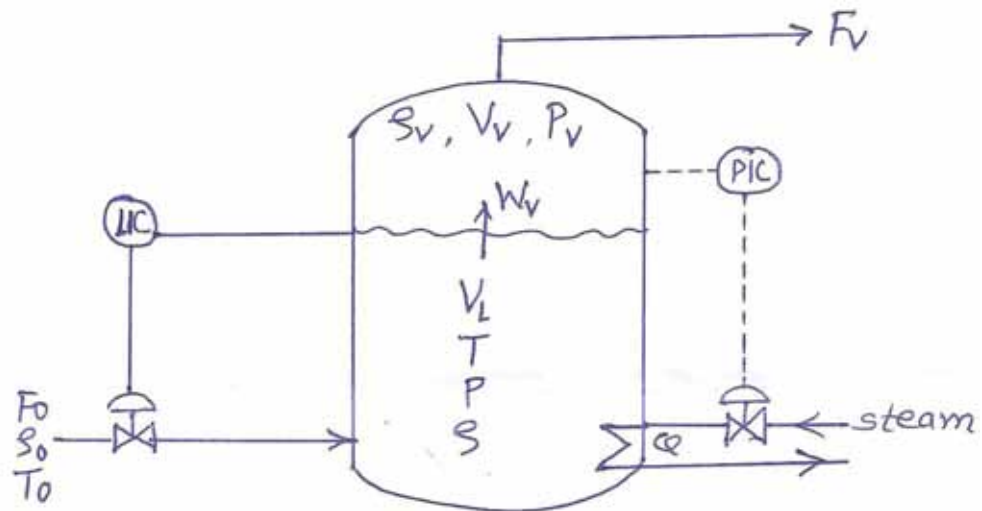

Develop simulation approach equations for:

1. Incompressible liquid
2. Vapor dynamics

OR

Q. 8 A An isothermal, irreversible reaction  $A \xrightarrow{k} B$  takes place in the 18  
liquid phase in a constant volume reactor. The mixing is not perfect. Observation of flow patterns indicates that a two tank system with back mixing approximates the imperfect mixing. Assuming  $F$  and  $F_R$  are constant, develop the simulation

equations describing the process.

- Q. 9     A     Explain in details, the effect of following states on a chemical process:     16
1. Equation of state
  2. Chemical equilibrium
  3. Phase equilibrium
  4. Raoult's law
- OR**
- Q. 10    A     Describe the development of state-space models for single loop controllers and MPC controllers with neat diagrams.     16
- Q. 11    A     Write note on process simulation using Artificial Neural Network.     08
- B     Enlist major advantages and disadvantages of Empirical models.     08
- OR**
- Q. 12    A     Leading to the development of Artificial Neural Network programming, develop equations describing a system of a non-interacting tank followed by two interacting tanks, with outlet of tank 3 as recycle to tank 1 through pump and provision of outlet from tank 2.     16

[Total No. of Questions: 12]

[Total No. of Printed Pages: 4]

UNIVERSITY OF PUNE

[4364]-727

B. E. (Petrochemical Engineering) Examination - 2013

RENEWABLE ENERGY SOURCES (ELECTIVE III)

(412410) (2008 Course)

[Time: 3 Hours]

[Max. Marks: 100]

**Instructions:**

- 1 Answer three questions from each Section.
  - 2 Answers to the two sections should be written in separate answer-books.
  - 3 Neat diagrams must be drawn wherever necessary.  
Figures to the right indicate full marks.
  - 5 Use of logarithmic tables, slide rule, Mollier charts, electronic pocket calculator and steam tables is allowed.
  - 6 Assume suitable data, if necessary.
- 
- 

**SECTION - I**

- Q.1 A) Non conventional energy resources are a must for sustainable word – Explain and elaborate with help of suitable examples. [8]
- B) Discuss various advantage and disadvantages of Renewable Energy sources. [8]

**OR**

- Q.2 A) With help of suitable examples discuss the major difficulties in getting energy from various Renewable Energy sources [8]
- B) Write a detailed not on current problems related to Energy in Global context. [8]
- Q. 3 A) With help of neat diagram explain the methods of measurement of solar radiation. [8]
- B) Solar energy has tremendous potential in countries like India- Elaborate with proper examples. Highlight the challenges involved in its commercialization. [8]

**OR**

- Q. 4 A) Write in details about the Solar Industrial heating systems with neat sketch. [8]

- B) How water desalination can be done effectively with help of solar energy explain in details. [8]
- Q. 5 A) With help of neat diagram explain pyrolysis of biomass. Discuss efficiency of process in context of Indian subcontinent. [9]
- B) What is Biorefinery – provide schematic diagram. discuss the different products achievable out of it. [9]
- OR**
- Q. 6 A) Composition of neem oil is given below:  
 C 16:0 = 15.5%, C 18:0 = 3.1%, C 18:1 6= 21.5% , C 18:1 12 =2.6%,  
 C 18:2 9, 12 = 53.6 % and C 18:3 5,9 ,13 rest  
 C18: 16 signifies an 18 carbon fatty acid chain with one double bond located at carbon 6.  
 Calculate amount of methanol required for trans- esterification of 5.7 lit of this oil, if 72% excess methanol based on stoichiometric requirement need to be used for complete conversion. Assume density of oil to be 0.89 and that of methanol be 0.8 kg/lit.  
 If overall 83.4% conversion be achievable, calculate mass of biodiesel and glycerol produced. Consider 6.5% of vegetable oil used undergoes saponification in presence of homogeneous NaOH catalyst. [18]
- SECTION II**
- Q. 7 A) How energy of waves can be captured – in this context discuss the design feature of helical turbine [8]
- B) Give a detailed account of Wind Energy potential in India. Compare advantage and disadvantages of wind energy [8]
- OR**
- Q. 8 A) Discuss the major challenge faced by OTEC technology. Highlight how the commercial feasibility of OTEC can be increased. [8]
- B) With help of neat diagram explain various parts of wind turbine generator units. [8]
- Q. 9 A) With help of schematic diagram explain the Geothermal Well and discuss the methods of extraction of energy out of it. [10]
- B) With a specific note to Indian subcontinent comment on origin and distribution of geothermal energy. [6]
- OR**
- Q. 10 A) Explain the process of liquid dominated (wet steam) system of geothermal energy extraction with neat sketch. [8]



- B) Describe various energy extraction technologies with hydrothermal (geothermal) resources. [8]
- Q. 11 A) List down five different types of fuel cells often used and compare between them based on types of electrolytes employed, operating ranges, fuel types and the oxidants utilized. [10]
- B) With help of schematic diagram explain the principle of operation of Fuel Cells. Comment on Cathode, Anode and the type of Electrolytes. [8]
- OR**
- Q. 12 A) Discuss the advantages and disadvantages of fuel cell. Write a detailed note on applicability of the Fuel Cells in Indian scenario. [9]
- B) Discuss the importance storage of electrical energy. Name different types of cell can be utilized. Discuss operation of any one of the cell. [9]

[Total No. of Questions: 9]

[Total No. of Printed Pages: 2]

UNIVERSITY OF PUNE

[4364]-728/263

B. E. (Petrochemical Engineering) Examination - 2013

PETROLEUM EXPLORATION AND PRODUCTION OPERATIONS (2003 and 2008 Course)

[Time: 3 Hours]

[Max. Marks: 100]

**Instructions:**

- 1 Answers to two sections should be written in separate answer-books.
- 2 Draw neat diagrams must be drawn wherever necessary.
- 3 All questions are compulsory

---

---

**SECTION - I**

- |      |   |   |    |
|------|---|---|----|
| Q.1  |   | Describe important physical and chemical properties of crude oil and natural gas.   | 15 |
|      |   | OR  |    |
| Q.2  | A | How is original oil and gas in place calculated? What is a difference between recoverable reserves and original oil and gas in place? | 10 |
|      | B | What happens to each barrel of oil produced in terms of approximate percentage usage in each important application?                   | 5  |
| Q. 3 | A | Explain important reservoir rock properties?  | 15 |
|      |   | OR  |    |
| Q. 4 | A | What is a Petroleum Geosystem? Explain different components of Petroleum Geosystems   | 15 |
| Q. 5 |   | Write short notes any four of the following:  | 20 |
|      |   | a) Reservoir drive mechanisms   |    |
|      |   | b) Reserves estimation  |    |
|      |   | c) Geophysical methods used in oil exploration  |    |
|      |   | d) Comparison of NYMEX, Brent crude, Middle East and Mumbai High crudes.  |    |
|      |   | e) Geological risk analysis.  |    |
|      |   | f) Formation evaluation   |    |
|      |   | g) Porosity logs.   |    |

## SECTION II

Q. 6	A	With the help of neat sketches, describe important components of a land rig.	15
Q. 7	A	What is well completion? Explain with the help of neat sketches various methods of oil well completion.	15
OR			
Q. 8	A	Explain important EOR methods.	10
	B	What are different artificial lift methods?	5
Q. 9	A	Write short notes on any four of the following: a) Factors that balance demand and supply of petroleum. b) India's hydrocarbon potential. c) Importance of natural gas for India industry. d) Environmental impact of produced water. e) Applications of microbiology in oil industry, and f) Deepwater resources.	20

---

[Total No. of Questions: 12]

[Total No. of Printed Pages: 3]

**UNIVERSITY OF PUNE**  
**[4364]-729**  
**B. E. (Petrochemical) Examination - 2013**  
**CATALYST SCIENCE AND TECHNOLOGY**  
**(2008 Course)**

[Time: 3 Hours]

[Max. Marks: 100]

**Instructions:**

- 1 Answers to the two sections should be written in separate answer-books.
- 2 Black figures to the right indicate full marks.
- 3 Neat diagrams must be drawn wherever necessary.
- 4 Use of logarithmic tables, slide rule, Mollier charts, electronic pocket calculator and steam tables is allowed.
- 5 Assume suitable data, if necessary.
- 6 Answer any three questions from Section I and any three questions from Section II

---

---

**SECTION - I**

- Q.1      A) With help of suitable example explain the importance of Catalysts in modern Chemical Processing Unit and Petrochemical Complexes. [8]  
            B) Define and explain: Selectivity, activity, functionality and active sites for Catalysts. [8]
- OR
- Q.2      A) Discuss the important characteristics of Industrial Catalysts. [6]  
            B) With the help of neat sketch explain how catalyst changes the reaction pathways. [6]  
            C) With help of proper example discuss Homogeneous Catalysis and its importance. [4]
- Q. 3      A) Differentiate between Physical Adsorption and Chemisorption. [6]  
            B) For the dual function catalyst, following gas phase reaction : [10]  
                     $W + Z \rightarrow \text{Products}$   
                    where, W and Z are adsorbed independently on different sites (i.e. dual functionality) and the reaction is between adsorbed A with adsorbed W molecules. Derive the rate expression considering Langmuir-Hinshelwood mechanism in terms of partial pressure of the respective components.  
                    Consider products are not adsorbed appreciably.  
                    If some inert gas Nitrogen is also Present which is appreciably adsorbed

on the surface, write down the modified rate expression.

OR

- Q. 4 A) Differentiate between Poisoning and Coke Deposition over catalyst surface. [6]  
B) Differentiate between Langmuir- Hinshelwood Model and Rideal Model of Catalytic reaction. [6]  
C) Write a short note on Regenerabilty of Spent Catalyst. [4]
- Q. 5 A) Discuss the need of Characterization of Catalysts. Name various important methods and discuss any of them in brief. [8]  
B) A commercial catalyst obtained by impregnation technique found to contain 7.2 wt% NiO over alumina support. The catalyst is then made into large cylindrical pellets for rate studies. Gross measurement of one pellet reveals following information; [10]  
Mass = 3.24 gm  
Diameter = 3 cm  
Thickness = 6 mm  
Volume = 3.3 cm<sup>3</sup>  
The Al<sub>2</sub>O<sub>3</sub> particle contain micropores and the peeling process introduce macropores surrounding the particles. The macropore volume of pellet is 0.65 cm<sup>3</sup> and the micropore volume is 0.4 cm<sup>3</sup>/g of particles. Based on these information calculate the following :  
i) The density of the pellet  
ii) The macropore volume in cubic meter per gram  
iii) The macropore void fraction in the pellet  
iv) The micropore volume fraction in the pellet.  
v) The solid fraction  
vi) The density of the particles

OR

- Q. 6 A) How can an industrial catalyst can be prepared using the precipitation technique – discuss with help of suitable example. [8]  
B) Low temperature (-195.8 °C) nitrogen adsorption data obtained for Fe-Al<sub>2</sub>O<sub>3</sub> ammonia catalyst. The results reported for 50.4 g sample: [10]

Pressure (mm Hg)	8	50	105	145	330	480
Vol. ads. (cm <sup>3</sup> ) at 0°C and 1 atm	103	130	148	163	221	294

Estimate the surface area of the catalyst.

Data: Density of liquid N<sub>2</sub> at – 195.8°C is 0.808 g/cm<sup>3</sup>

## SECTION II

- Q. 7      A) What are the supported metal catalysts? How can they be synthesized? [8]  
            Discuss their commercial applications.  
            B) With help of neat diagram explain the structure of Zeolites. Mention [8]  
            application of Zeolites in Petrochemical Complex and Refineries.
- OR
- Q. 8      A) What are Sintering? How can it be reduced? [6]  
            B) With help of suitable examples elaborate the shape selectivity of Zeolites [6]  
            – Highlight its commercial applications.  
            C) Write a short note on Promoters [4]
- Q. 9      A) Discuss the need of Isomerization in a Petroleum Refinery. Briefly [8]  
            explain the Catalytic Isomerization process with a special emphasis on  
            catalyst and the reactors involved along with its operating conditions.  
            B) With help of neat diagram explain the process of Naphtha reforming. In [8]  
            this context discuss the dual functionality of the catalysts involved.  
            Mention briefly on the catalyst deactivation and its regeneration  
            processes.
- OR
- Q. 10     A) Draw a sketch of Trickle Bed Reactor with inter-stage cooling. Discuss [6]  
            its operation for any important industrial operation.  
            B) Comment on processing conditions and performance characteristic for [4]  
            hydro-treating of Light Petroleum Distillate and Heavy Resid Fractions.  
            C) Write a short note of Fluidized Catalytic Cracking and its importance – [6]  
            Provide neat diagram.
- Q.11     A) Describe the production of synthesis gas via steam reforming process. [9]  
            Provide the details of reaction conditions. Comment on the feed and the  
            reactor design aspects.  
            B) Discuss Methanol Synthesis catalysts and their performance. Draw a [9]  
            schematic diagram of multiphase reactor used of Methanol manufacture,  
            discuss all technical aspects associated with the design of the reactor.
- OR
- Q. 12     A) Write Short Notes on (Any three) [18]  
            i) Ammonia Reactor  
            ii) Manufacture of Phthalic Anhydride  
            iii) Fischer- Tropsch Process  
            iv) Industrial Scale Styrene Production  
            v) Selection of Multiphase Catalytic reactor